

CROSS SECTION 'A'

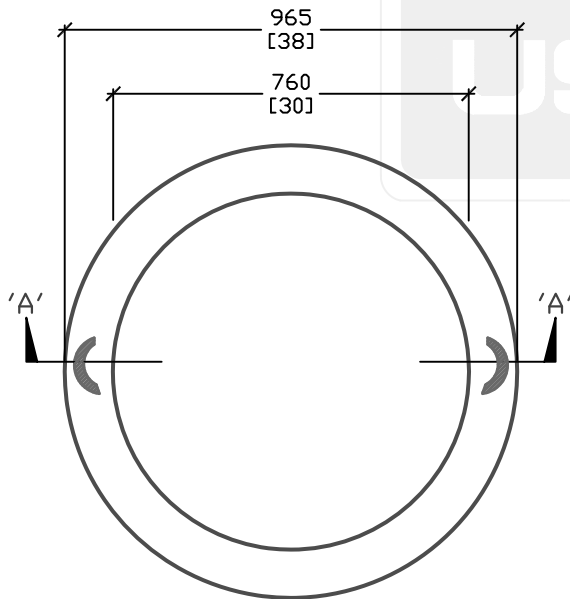

PLAN VIEW

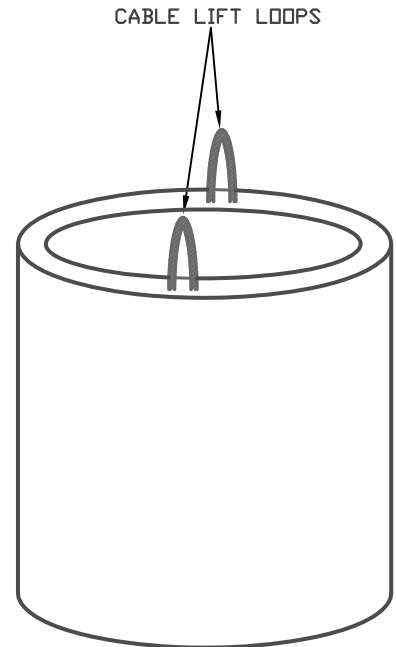

ISOMETRIC

ALL DIMENSIONS DEFAULT TO MILLIMETERS

mm
[in.]



61 BONGARD AVE
OTTAWA, ON,
PH: 800.267.6466
FAX: 613.225.1681

www.utilitystructures.com

NOTES:

USED TO PROTECT WATER & POWER
ON CONSTRUCTION SITES
WWM & STEEL REINFORCED

*CSA 23.4-05
35MPa (5000psi) AT 28 DAYS
6-8% AIR ENTRAINED

REV.#	MM/DD/YYYY	PREP.
1	AUG/26/2008	LRW
2	MAR/02/2009	LRW

E-95

STANDPOST PROTECTOR

WEIGHT = 550kg/1200lbs

.75m(H) x 760mm dia.