

CROSS SECTION 'A'

CROSS SECTION 'B'

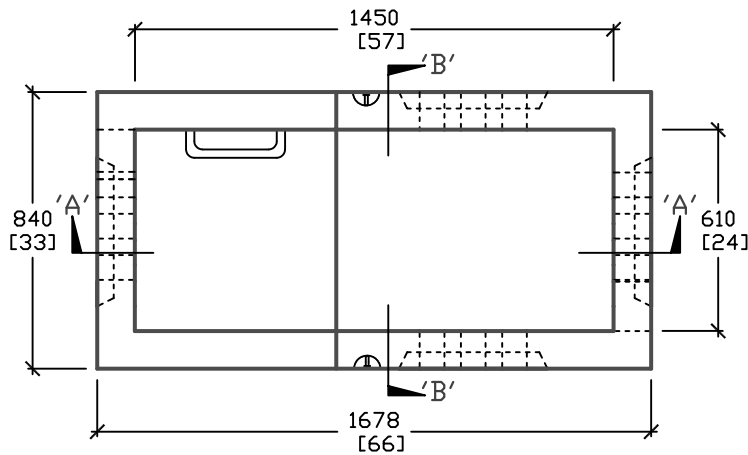

PLAN VIEW

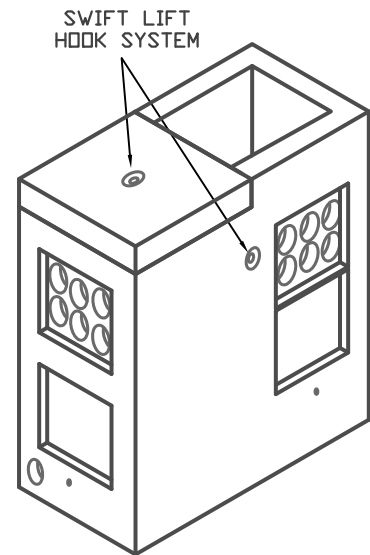

ISOMETRIC VIEW

ALL DIMENSIONS DEFAULT TO MILLIMETERS

mm
[in.]



61 BONGARD AVE
OTTAWA, ON,
PH: 800.267.6466
FAX: 613.225.1681

www.utilitystructures.com

NOTES:

AS PER O.P.S.D. 2111.02
DESIGNED TO CL-625-DNT TRUCK
LIVE LOADING AS PER CSA S6-06

*CSA 23.4-05
35MPa (5000psi) AT 28 DAYS
6-8% AIR ENTRAINED

REV.#	MM/DD/YYYY	PREP.
1	OCT/09/2008	LRW
2	FEB/26/2009	LRW

E-23

ELECTRICAL MANHOLE

WEIGHT = 2200kg/4800lbs

610mm x 1450mm [I.D.]