

CROSS SECTION 'A'

CROSS SECTION 'B'

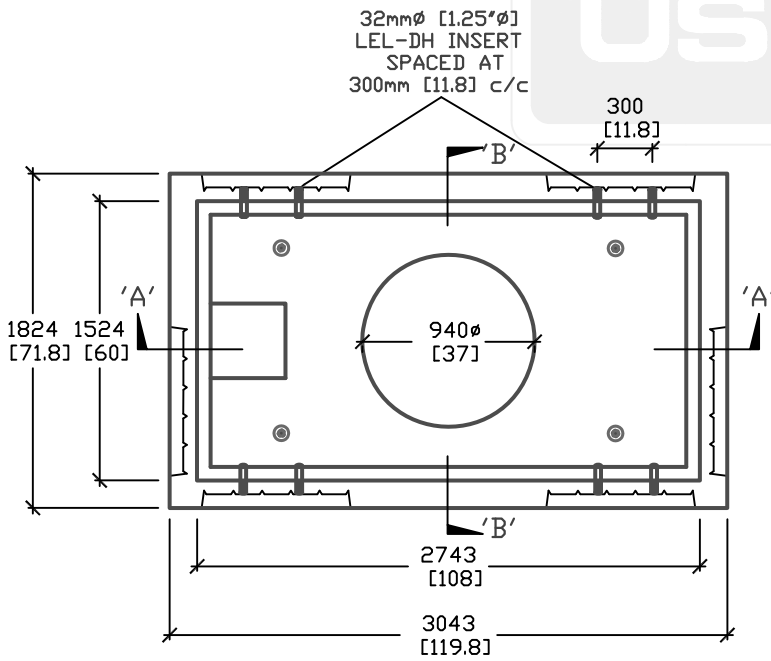

PLAN VIEW

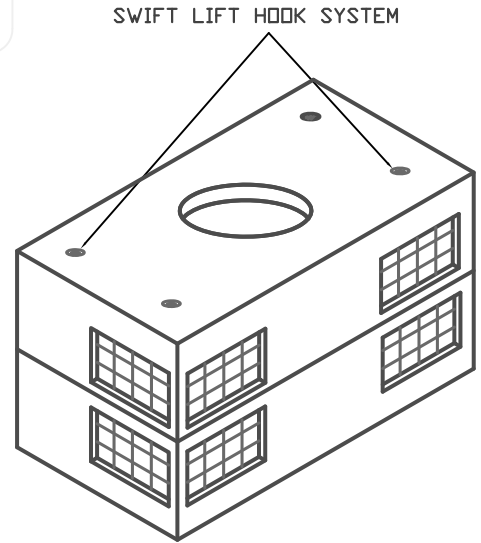

ISOMETRIC VIEW

ALL DIMENSIONS DEFAULT TO MILLIMETERS

mm
[in.]



61 BONGARD AVE
OTTAWA, ON,
PH: 800.267.6466
FAX: 613.225.1681

www.utilitystructures.com

NOTES:

DESIGNED TO CL-625-DNT TRUCK
LIVE LOADING AS PER CSA S6-06
AS PER HYDRD OTTAWA UCS0013

*CSA 23.4-05
35MPa (5000psi) AT 28 DAYS
6-8% AIR ENTRAINED

REV.#	MM/DD/YYYY	PREP.
3	MAR/26/2009	LRW
4	NOV/19/2009	LRW

E-35

5'x9' ELECTRICAL MANHOLE

WEIGHT = 10800kg/23760lbs

1524mm x 2743mm [I.D.]