

**CROSS SECTION 'A'**

**CROSS SECTION 'B'**

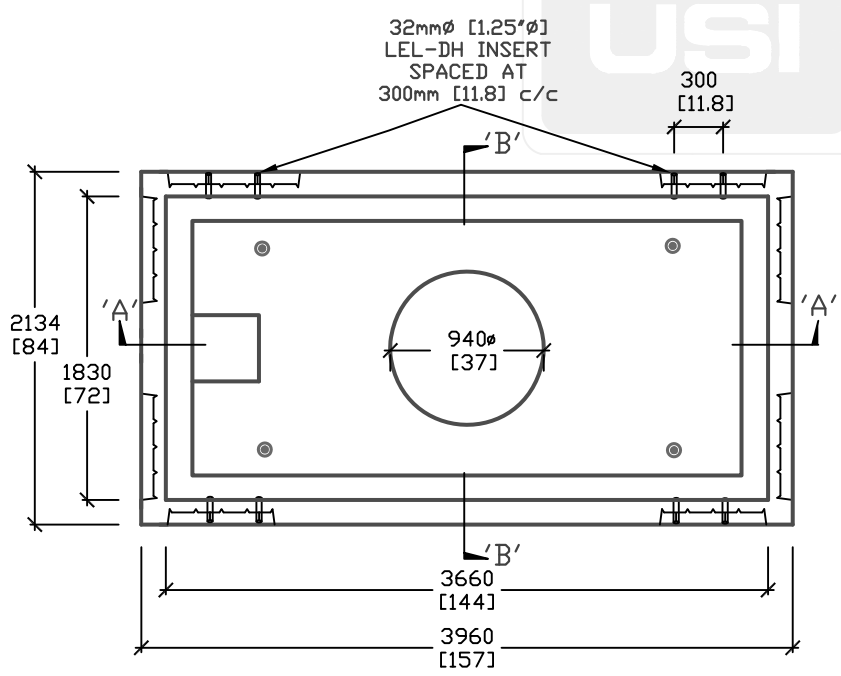

**PLAN VIEW**

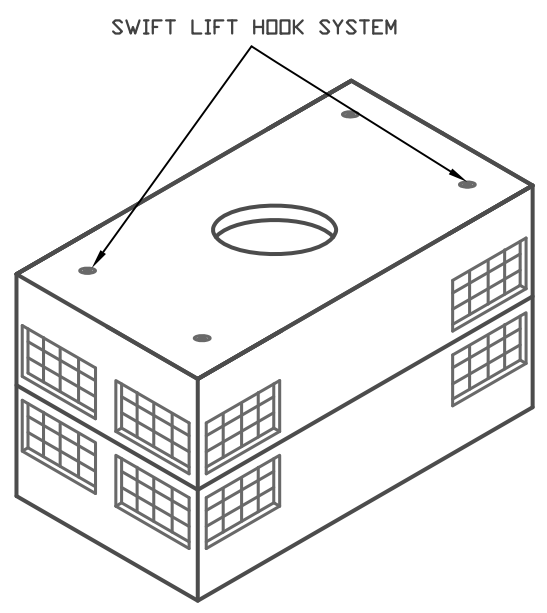

**ISOMETRIC VIEW**

ALL DIMENSIONS DEFAULT TO MILLIMETERS

mm [in.]



61 BONGARD AVE  
OTTAWA, ON,  
PH: 800.267.6466  
FAX: 613.225.1681

www.utilitystructures.com

**NOTES:**  
AS PER HYDRO OTTAWA UCS0014  
DESIGNED TO CL-625-DNT TRUCK  
LIVE LOADING AS PER CSA S6-06

\*CSA 23.4-05  
35MPa (5000psi) AT 28 DAYS  
6-8% AIR ENTRAINED

REV.#	MM/DD/YYYY	PREP.
3	FEB/26/2009	LRW
4	NOV/19/2009	LRW

**E-36**  
6' x 12' ELECTRICAL MANHOLE

WEIGHT = 15500kg/34000lbs

**1830mm x 3660mm [I.D.]**