

CROSS SECTION 'A'

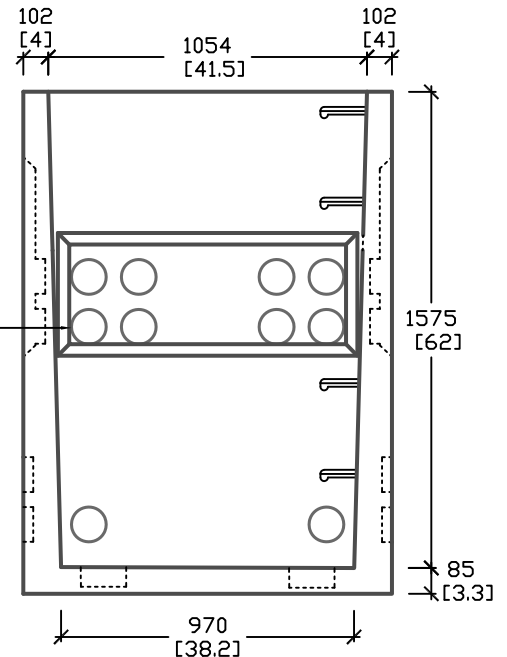

CROSS SECTION 'B'

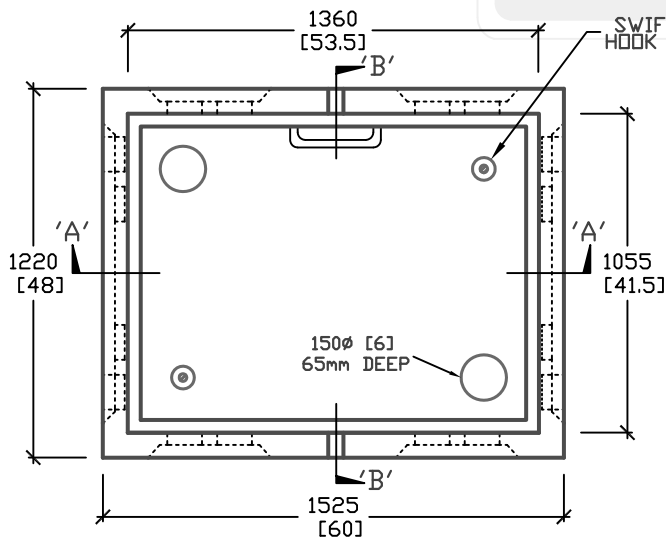

PLAN VIEW

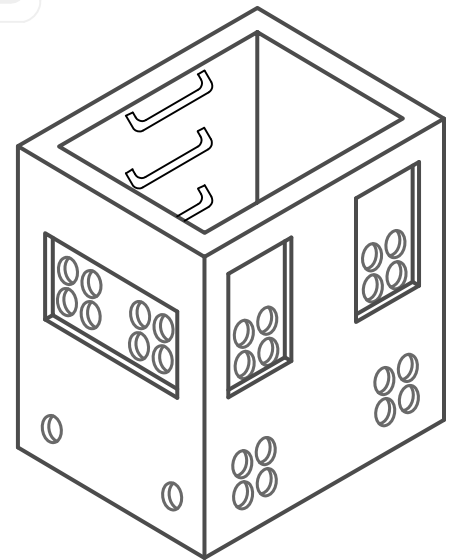

ISOMETRIC VIEW

ALL DIMENSIONS DEFAULT TO MILLIMETERS

mm [in.]



61 BONGARD AVE
OTTAWA, ON,
PH: 800.267.6466
FAX: 613.225.1681

www.utilitystructures.com

NOTES:

DESIGNED TO CL-625-DNT TRUCK
LIVE LOADING AS PER CSA S6-06
USE WITH E63 PAD

*CSA 23.4-05
35MPa (5000psi) AT 28 DAYS
6-8% AIR ENTRAINED

REV.#	MM/DD/YYYY	PREP.
1	OCT/09/2008	LRW

E-62

ELECTRICAL MANHOLE BASE

WEIGHT = 2150kg/4800lbs

1220mm x 1520mm [O.D.]