

CROSS SECTION 'A'

CROSS SECTION 'B'

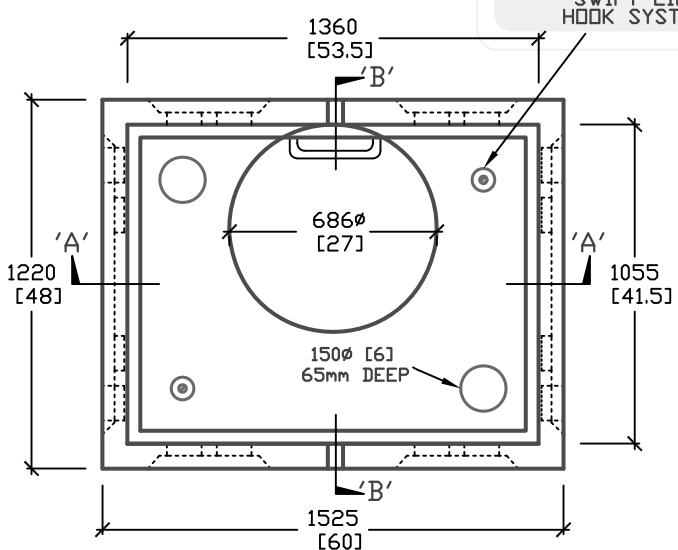

PLAN VIEW

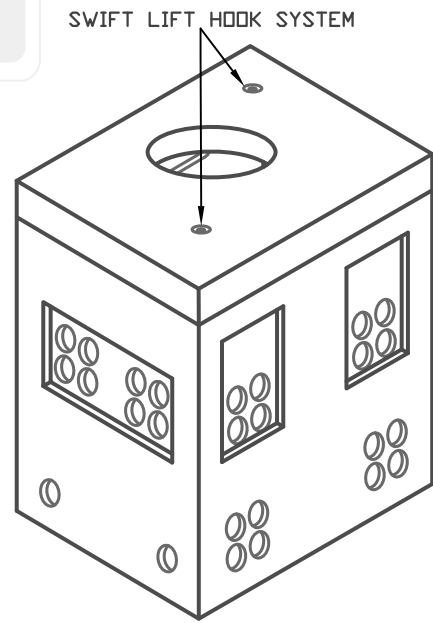

ISOMETRIC VIEW

ALL DIMENSIONS DEFAULT TO MILLIMETERS

mm [in.]



61 BONGARD AVE
OTTAWA, ON,
PH: 800.267.6466
FAX: 613.225.1681

www.utilitystructures.com

NOTES:
DESIGNED TO CL-625-DNT TRUCK
LIVE LOADING AS PER CSA S6-06

*CSA 23.4-05
35MPa (5000psi) AT 28 DAYS
6-8% AIR ENTRAINED

REV.#	MM/DD/YYYY	PREP.
2	OCT/28/2008	LRW

E62^C / E63_W
ELECTRICAL MANHOLE BASE
AND PAD

WEIGHT = 3050kg/6780lbs

1.86m(H) x 1055mm x 1360mm