

0.15m x 810mm [6" x 32"]  
ELECTRICAL FRAME AND COVER  
TAMPER PROOF

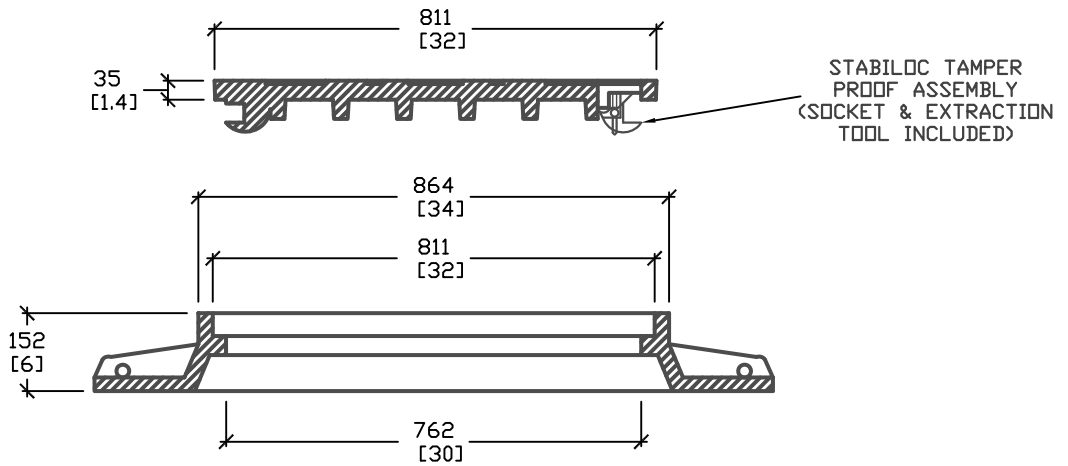

N.T.S.

ALL DIMENSIONS DEFAULT TO MILLIMETERS mm (inches)

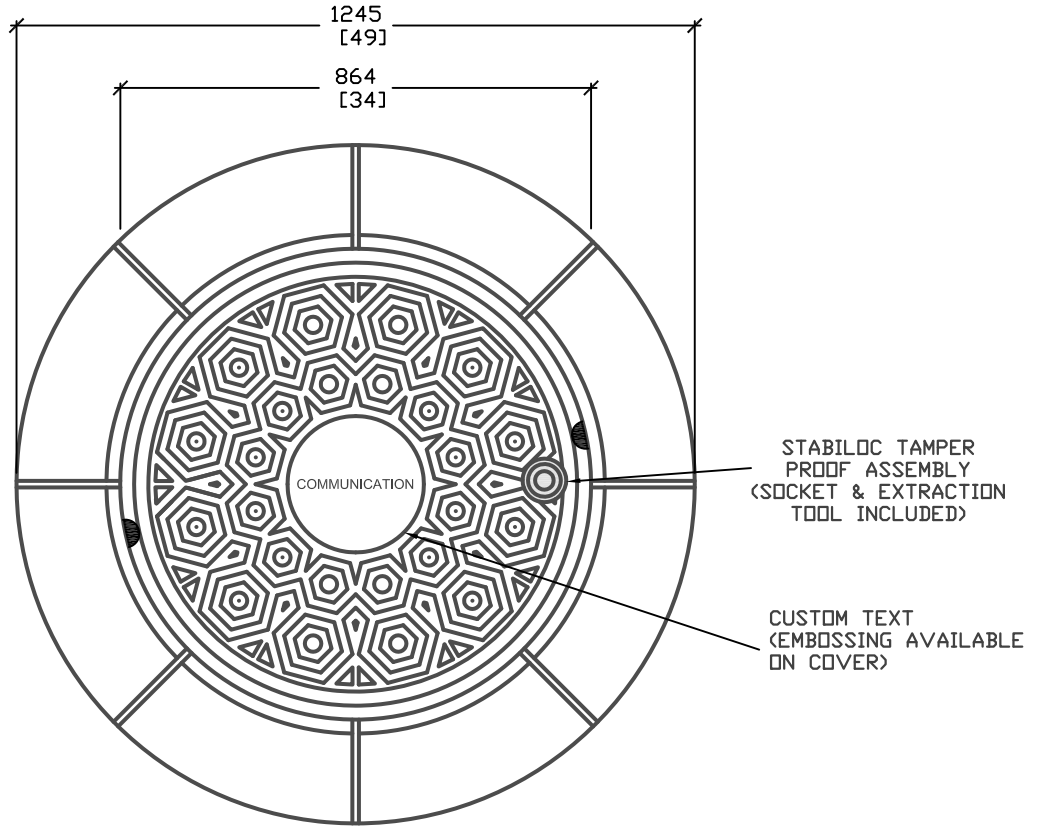

61 BONGARD AVE  
OTTAWA, ON,  
PH: 800.267.6466  
FAX: 613.225.1681

www.utilitystructures.com

NOTES:

SIMILAR TO C-43A  
WITH STABILOC SECURITY SYSTEM  
USED FOR 940mm DIA. OPENING

CAST-IRON

REV.#	MM/DD/YYYY	PREP.
1	SEPT/16/2011	EG

**F-5-TP**

ROUND FRAME & ROUND COVER  
C/W TAMPER PROOF ASSEMBLY

WEIGHT = 320kg/750lbs

**.15m(H) x 811mm dia.**