

• CUSTOM BOLT CIRCLE DIAMETER AVAILABLE  
 • CUSTOM DUCT ENTRIES AVAILABLE

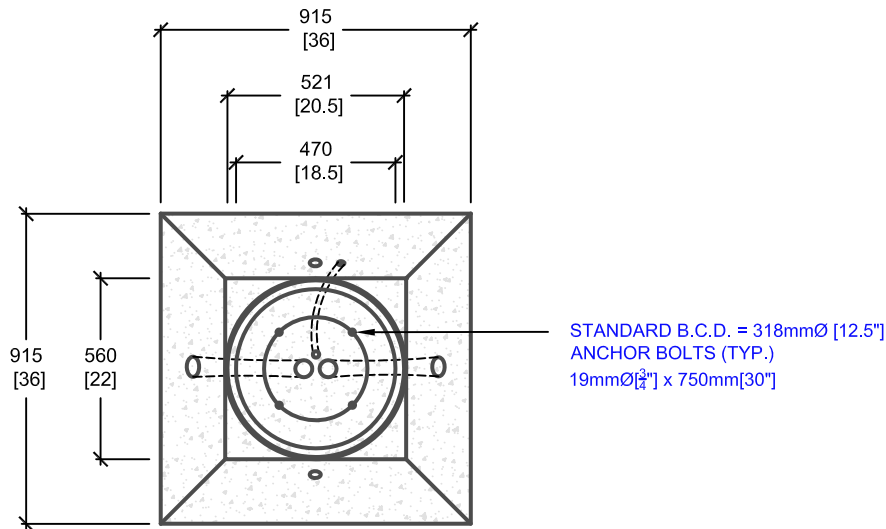

**PLAN VIEW**

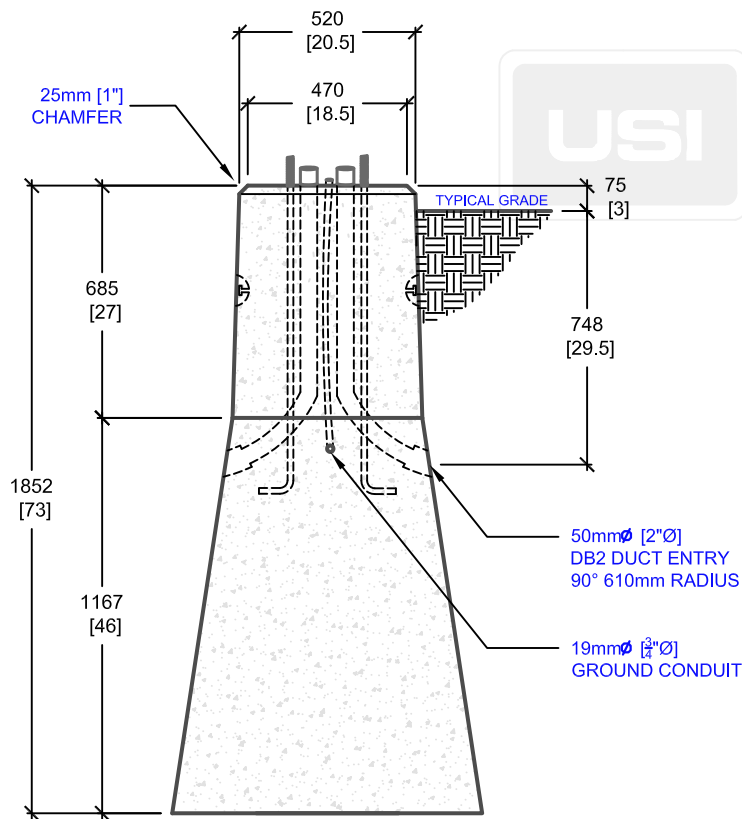

**SIDE ELEVATION**

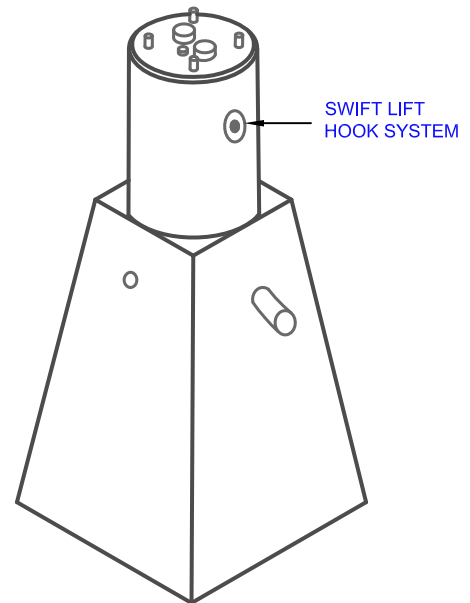

**ISOMETRIC VIEW**

mm  
 [Inches]  
 ALL DIMENSIONS DEFAULT TO MILLIMETRES



**UTILITY STRUCTURES INC.**

61 BONGARD AVE | OTTAWA, ON | K2E 6V2  
 T: 613.225.6398 F: 613.225.1681 TF: 800.267.6466

[www.utilitystructures.com](http://www.utilitystructures.com)

**CONSTRUCTION DETAILS:**

- AS PER CITY OF OTTAWA LID002B TYPE "A"
- CAN ACCOMMODATE A 37' POLE ABOVE GRADE
- BOLT CIRCLE DIAMETER: 318mmØ [12.5"Ø]
- CUSTOM BOLT CIRCLE DIAMETER AVAILABLE

- CSA 23.4-05
- 35 MPa (5000psi) AT 28 DAYS
- STRIPPING STRENGTH: MIN. 20 MPa(2900psi)
- 5-8% AIR ENTRAINED
- EXPOSURE CLASS: C-1
- REINFORCING: STEEL TO CSA CAN A23.1

**PRODUCT CODE:**

**P-52RT**

6' SQUARE PYRAMID POLE BASE  
 WITH ROUND TOP

**DIMENSIONS:**

**1.85m(H) X 470mm dia.**

**TOTAL WEIGHT:**

**1,977 kg / 4,360 lbs**

**REVISION DATE:**

**JULY 31, 2018**

**REV. #2**