

PLAN VIEW

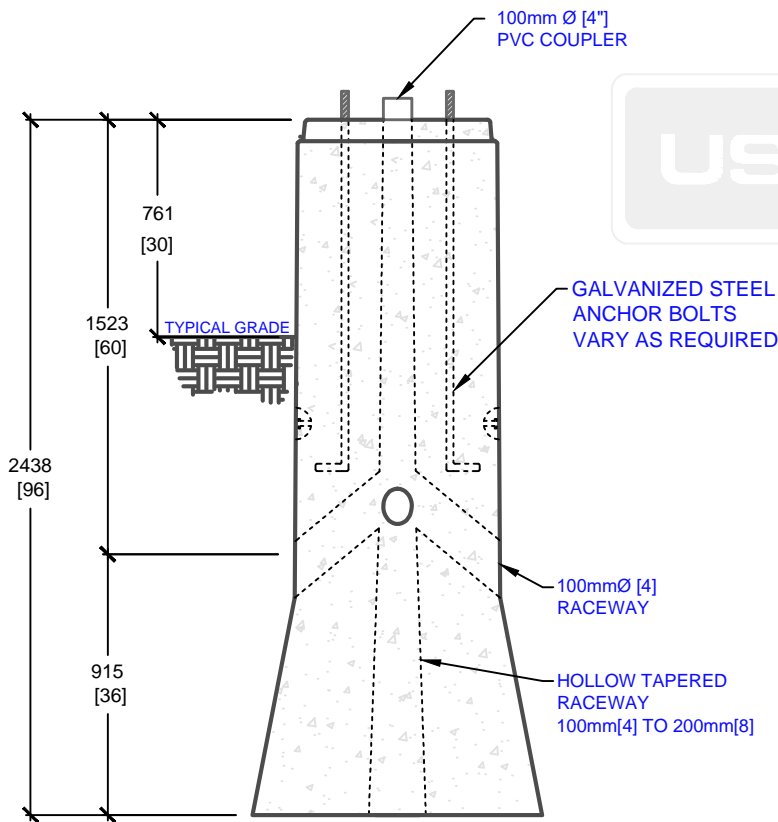

SIDE ELEVATION

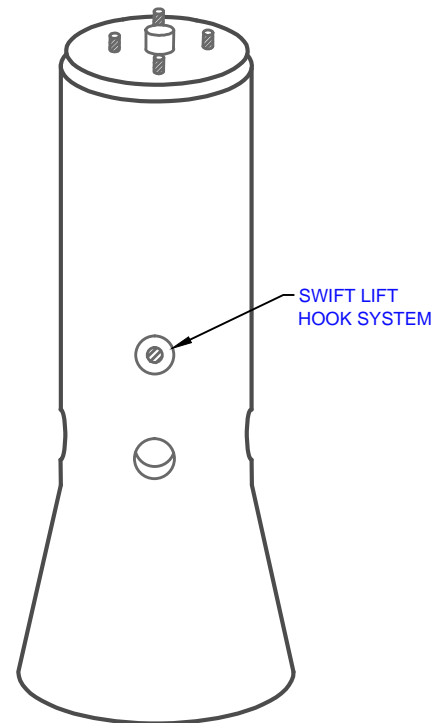

ISOMETRIC VIEW

mm
[Inches]
ALL DIMENSIONS DEFAULT TO MILLIMETRES



UTILITY STRUCTURES INC.

61 BONGARD AVE | OTTAWA, ON | K2E 6V2
T: 613.225.6398 F: 613.225.1681 TF: 800.267.6466

www.utilitystructures.com

CONSTRUCTION DETAILS:

- CAN ACCOMMODATE A 35' POLE ABOVE GRADE
- AVAILABLE IN VARIOUS COLOURS & FINISHES
- ADJUSTABLE BOLT CIRCLE DIAMETER
- BOLT CIRCLE DIAMETER: 203mm[8"] TO 380mm[15"]

- CSA 23.4-05
- 35 MPa (5000psi) AT 28 DAYS
- STRIPPING STRENGTH: MIN. 20 MPa(2900psi)
- 5-8% AIR ENTRAINED
- EXPOSURE CLASS: C-1
- REINFORCING: STEEL TO CSA CAN A23.1

PRODUCT CODE:

P-55

8' PARKING LOT POLE BASE

DIMENSIONS:

2.44m(H) X 690mm dia.

TOTAL WEIGHT:

3,000 kg / 6,600 lbs

REVISION DATE:

JULY 31, 2018

REV. # 2